

# GEARWHEEL DEPOSITOR DEPOSITING MACHINE

High capacity dosing



Scan the code  
and discover  
more info!



# GEARWHEEL DEPOSITOR DEPOSITING MACHINE

BAKON designs and manufactures standardized and customized depositing, spraying and cutting machines as well as production lines for efficient and high-volume processing of pastry products. BAKON stands for advanced technology and reliability.

## High-capacity depositing with the BAKON Gearwheel Depositor

Dose high-volumes of products like mousse, creams, eclairs, macarons, batters, cookies, marzipan, almond paste, health bars, short dough and soft cheese with the BAKON Gearwheel Depositor. Whether you want to speed up your existing production or produce a totally new product BAKON is your partner.



Create, save and choose your unique machine settings in the full colour touchscreen panel before positioning your product trays on the conveyor. Changing from one to the other product is now a matter of seconds thanks to the saved recipes and the simple swapping of accessories which puts your production up and running with a minimum of down time. Your product trays can easily be positioned on the conveyor belt due to an adjustable guide rail at the infeed of the conveyor.

When the machine is started, your product tray will be transported underneath the depositing head of the Gearwheel depositor which knows exactly when to start and stop the depositing cycle of your product on the tray due to a sensor on the conveyor. After your depositing cycle is finished with the required amount of product, it leaves the machine ready to be processed further depending on your product.

This solution can be easily integrated into existing production lines, whether you want to use a second Gearwheel Depositor to add another layer of product or feed the tray to an oven or freezer conveyor.

## Your benefits

- Production efficiency and increase in capacity
- Reduction labor costs
- Accurate weight control
- Easy to integrate in (existing) production lines
- Full control of the whole production process



- Working width up 1200 mm
- Pump housing with ceramic coating
- Servo drives
- Feeding rollers for constant pressure in pump housing
- Stainless steel gears
- Easy template change
- Storage of 100 machine recipes
- Advanced full color touchscreen
- Available on C-frame and H-frame (above 800 mm)
- Completely stainless steel



Capacity: medium to high



The GEARWHEEL DEPOSITOR MACHINE is available as stand-alone and inline machine.



Cream, mousse, soft cheese, éclair, macarons, cookies, batters, marzipan, almond paste and short dough. We underline the importance of understanding your product, ingredients and process in configuring your solution. BAKON will look together with you to increase your productivity.

*\* We are happy to test your ingredients.*



Get to know all our depositing solutions





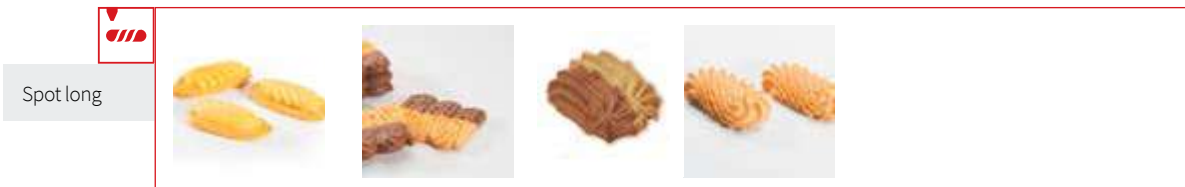
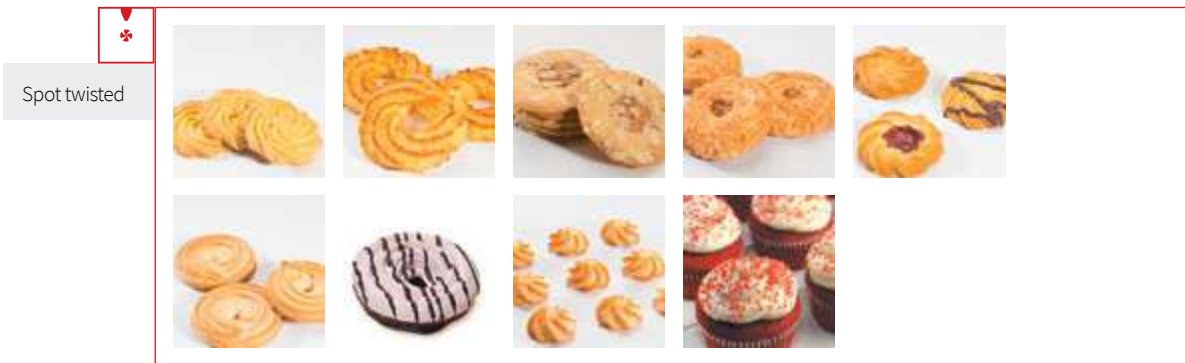

1 YEAR FOR FREE

# REDCASE<sup>®</sup>

SERVICE & SUPPORT PROGRAM

Optimize your business process, increase your production capacity and reduce machine downtime with the RedCase<sup>®</sup> service and support program of BAKON. Want to know more about RedCase<sup>®</sup>? Scan the QR code!





○ Denester



○ Release Agent Sprayer



○ Transfer Pump



GEARWHEEL DEPOSITOR



○ Strewer



○ Robotic arm

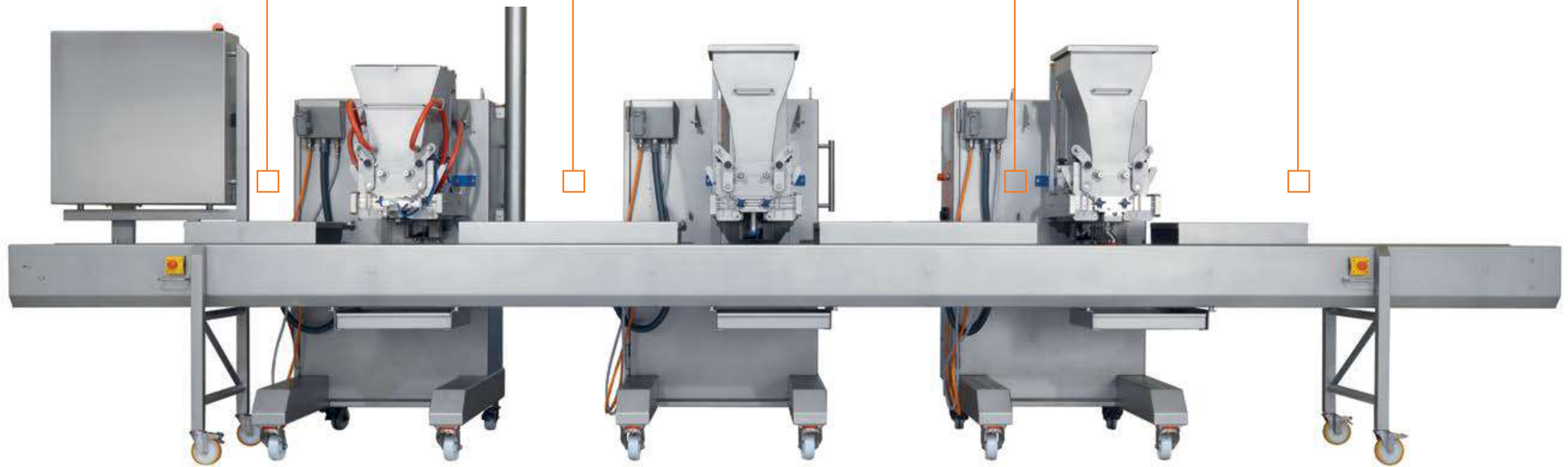

Complete production line with integrated Gearwheel Depositors





# BAKON.COM



**Innovation and Experience Center**  
Amundsenweg 29a  
4462 GP Goes  
The Netherlands

**Manufacturing facility**  
Stanleyweg 1  
4462 GN Goes  
The Netherlands

+31 (0)113 244 330  
info@bakon.com  
bakon.com



Contact us



Follow Bakon!



STAY INFORMED  
SIGN UP FOR OUR  
NEWSLETTER

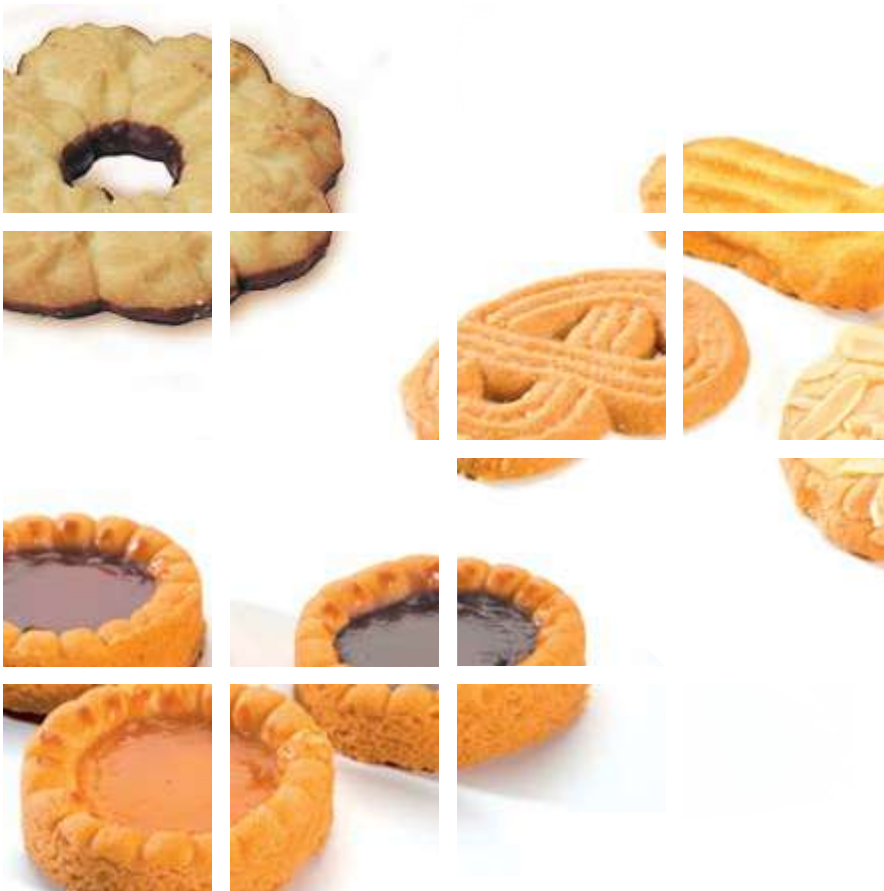

Through energy-saving measures, such as dimensioning of electrical power and – where possible – use of recyclable materials, BAKON commits to dealing responsibly with the environment.